

HISTORY X.COUNT	DATE	ECN NO.	REV.	REVISION	SIGN.
△ x1	22/APR/08	N200805001	B	變更孔徑公差，3.25mm改為3.30mm。	Chris
△ x1	01/DEC/09	N200912001	C	增加零件標示。	Chrls
△ x2	01/JUL/10	N201007001	D	使圖面與實物相符。	LEO

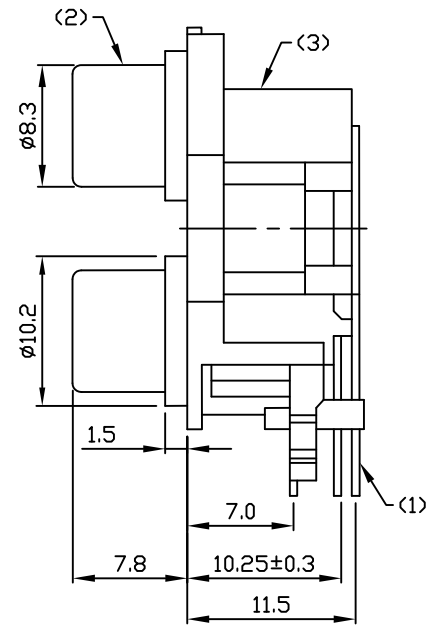
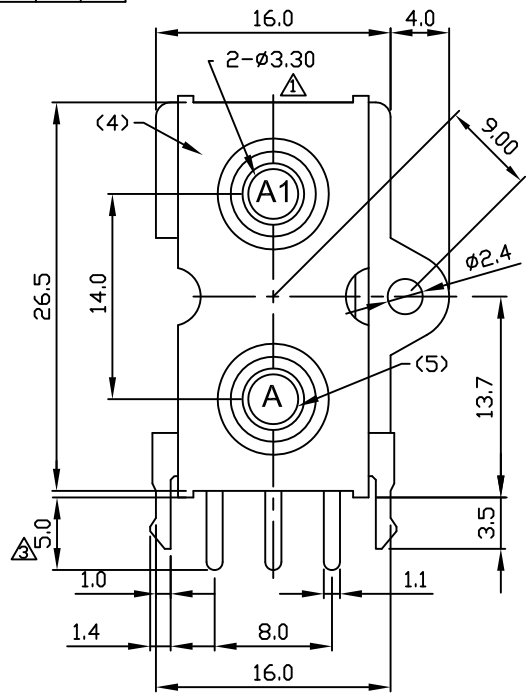

LPA0860 □ □ △ - □ □ - A A1
 (1) (2) (3) (4) (5) (6) (7)

(1):Series No.

(2):Terminal Type

	B	S	V
90°	180°	Wire Soldering	Height=24.5mm

(3):Metal Shielding

	M
Without Shielding	With Shielding

(4):Optional Plastic Material Code

(5):Terminal Plating

3	5
Sn/Cu	Gold 2u"

(6):Bushing Plating

2	5
Nickel	Gold 2u"

(7):Insulator Color Code:(A — A1)

1	2	3	4	5
Black	Red	White	Yellow	Blue
6	7	8	9	
Gray	Green	Orange	Brown	

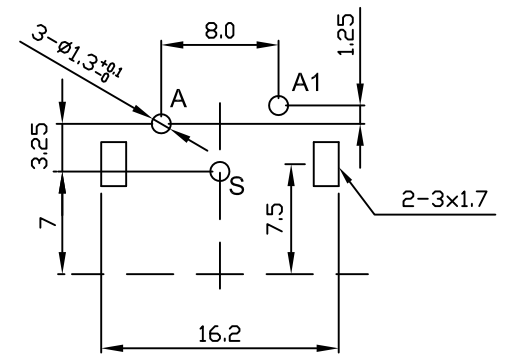

P.C.B LAYOUT(±0.1)
(BOTTOM VIEW)

CIRCUIT	WASHER COLOR
A1	A1
A	A
S	
AA1	

NO	PART NAME	Q'TY	MATERIAL	PLATED	REMARK
5	WASHER	2	NYLON66 94V2		
4	COVER	1	PBT-94V0 G15		BLACK
3	BASE	1	PBT-94V0 G15		BLACK
2	EARTH TERMINAL	1	BRASS	NICKEL	
1	TIP	2	BRASS	Sn/Cu	



LIH SHENG PRECISION INDUSTRIAL CO., LTD.

TOLERANCE	Material	PART NAME	RCA JACK		
X ±0.5	Thickness	PART NO.	LPA0860-32-		
X.X ±0.3		DATE	09/16/05'	REV: D	△
X.XX ±0.15	Disposal	DRAW	CHECK	APPROVE	
	UNIT	SCALE	Chris	Ken	Ken
	mm	2:1			